



High quality, Quick delivery

High purity and high density to realize the extremely long life

We have unique clad technic with steel and titanium too

Chrome Anode

High pressure extrusion • high purity lead alloy anode

Chrome plating • Aluminium anodizing • Acid electrolysis etc.

Standard / Variation

Any shapes and sizes include cross section and handle type can be made.
We will deliver them very quickly.

■ SK(flower)type lead-tin alloy

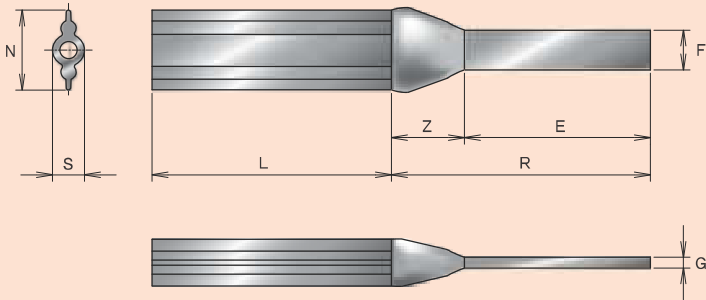

| standards | N | S | Z | R | E | F | G | L |
|-----------|-----|----|-----|-----|-----|----|---|----------|
| SK 40 | 40 | 18 | 40 | 190 | 150 | 25 | 3 | variable |
| SK 50 | 50 | 24 | 50 | 200 | 150 | 30 | 3 | |
| SK 60 | 60 | 29 | 60 | 210 | 150 | 30 | 4 | |
| SK 70 | 70 | 30 | 70 | 250 | 180 | 40 | 4 | |
| SK 100 | 100 | 29 | 100 | 270 | 180 | 50 | 5 | |

※ L = standard body length:500mm(MAX about 5m) *size = mm
※ F·G = copper plate of feed part:It may be arranged depend on current

■ SH(star)type lead-tin alloy

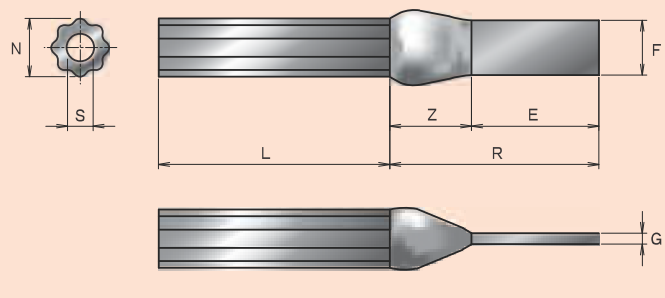

| standards | N | S | Z | R | E | F | G | L |
|-----------|----|----|----|-----|-----|----|---|----------|
| SH 32 | 32 | 14 | 35 | 185 | 150 | 25 | 3 | variable |
| SH 35 | 35 | 14 | 35 | 185 | 150 | 25 | 3 | |
| SH 38 | 38 | 18 | 40 | 190 | 150 | 30 | 3 | |
| SH 42 | 42 | 22 | 45 | 195 | 150 | 30 | 4 | |

※ L = standard body length:500mm(MAX about 5m) *size = mm
※ F·G = copper plate of feed part:It may be arranged depend on current

■ SN(wave)type lead-tin alloy

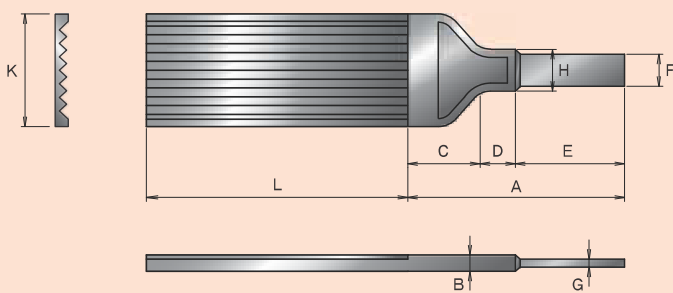

| standards | A | B | C | D | E | F | G | H | K | L |
|-----------|-----|----|-----|-----|-----|----|----|-----|----|----------|
| SN 50 | 240 | 11 | 60 | 30 | 150 | 15 | 3 | 22 | 50 | variable |
| SN 70 | 242 | 11 | 60 | 32 | 150 | 20 | 3 | 26 | 70 | |
| SN 90 | 240 | 11 | 60 | 30 | 150 | 25 | 4 | 32 | 90 | |
| SN 125 | 280 | 15 | 100 | 180 | 40 | 5 | 50 | 125 | | |
| SN 150 | 280 | 15 | 100 | 180 | 60 | 6 | 70 | 150 | | |

※ L = standard body length:500mm(MAX about 5m) *size = mm
※ F·G = copper plate of feed part:It may be arranged depend on current

[Other variation samples]

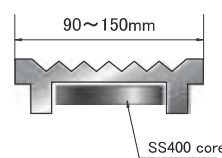

Wave type SN with flat steel

We put flat steel on the back to prevent from distortion.
It is better for long length type.
(We have made longer than 7m.)

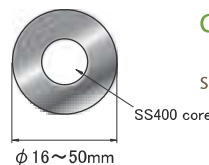

Circle type

simple circle section

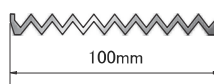

Cathode for anodizing

This is used only Pb100% for aluminium anodizing.



<http://www.spf.co.jp/>

E-MAIL



info@spf.co.jp

Europe
USA
Japan
Taipei
Thailand
Vietnam

TEL +31-45-523-1474
TEL +1-713-683-9373
TEL +81-52-871-4121
TEL +886-2-2666-5920
TEL +66-2235-3841
TEL +84-4-3974-4620

FAX +31-45-523-0470
FAX +1-713-683-0075
FAX +841-52-872-1397
FAX +886-2-2666-5928
FAX +66-2235-3840
FAX +84-4-3974-4622